

**Topic:**

- What does "RC Servo Set Value" mean?
- Where is a "RC Servo Set Value" in use?

**Solution:**

The abbreviation "RC" stands for "Remote Control". Professional and non-professional remote control applications commonly command the motor controller by a pulse with a varying pulse length within defined limits. This kind of commanding corresponds to a long time ago established standard in the special field of remote control applications.

The "RC servo set value" has a variable pulse length in between minimum 1 millisecond up to maximum 2 milliseconds.

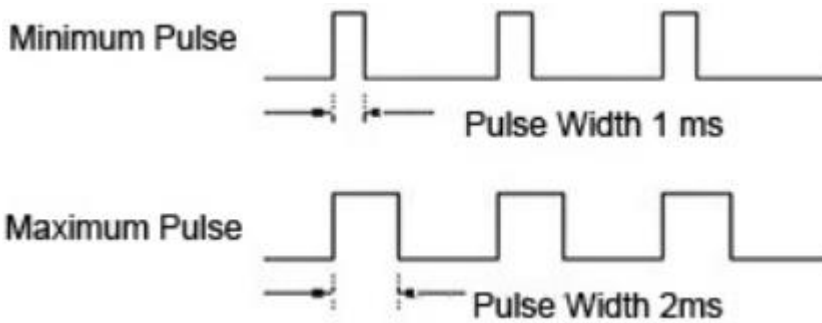

Typical remote control applications using this kind of drive commanding are drones or any other kind of model-building devices (e.g. unmanned aircrafts or RC vehicles).

The technical specification of the RC servo signal can be found in the chapter "Digital Input 1" of the ESCON's "Hardware Reference". In case of an "ESCON 50/5" it states the following:

**3.3.5.1 Digital Input 1**

Input voltage	0...36 VDC
Max. input voltage	+36 VDC / -36 VDC
Logic 0	typically <1.0 V
Logic 1	typically >2.4 V

RC Servo cycle duration	3...30 ms
RC Servo pulse length	1...2 ms

- The 1 ms pulse length corresponds to a configurable minimum command speed (in speed control mode) or minimum command current (in case of current control).
- The 2 ms pulse length corresponds to a configurable maximum command speed or maximum command current. These limits can be configured by the "Startup" wizard of "ESCON Studio".

## maxon motor control

maxon motor ag  
Brünigstrasse 220  
CH – 6072 Sachseln  
[www.maxonmotor.com](http://www.maxonmotor.com)

### ESCON: RC Servo Set Value

Version: 1.0 (Eng.)  
Author: WJ  
Date: 2018-07-03

#### **Important note (just special for the ESCON):**

It is just possible to use RC servo set value by the digital input 1.

If the digital input 1 is already in use by another functionality (e.g. "Enable"), the "PWM set value" and "RC servo set value" is not available anymore by the configuration. If "PWM set value" or "RC servo set value" is required by the application, ensure that "Enable" and other required functions are assigned to other digital inputs than digital input 1.